

## PART NUMBER

**ESM6, ESM8, ESM12, ESM16, ESM18,  
 ESM24, ESM30, ESM36, ESM42, ESM48**

Multigang Stainless Steel Switch Panel

PART NUMBER:

ESM

X

X

-

XX

NO. OF SWITCHES	LABEL	SWITCH COLOUR
6 = 6	L = Yes	WE = White
8 = 8	(leave blank) = No	BL = Black
12 = 12		
16 = 16		
18 = 18		
24 = 24		
30 = 30		
36 = 36		
42 = 42		
48 = 48		

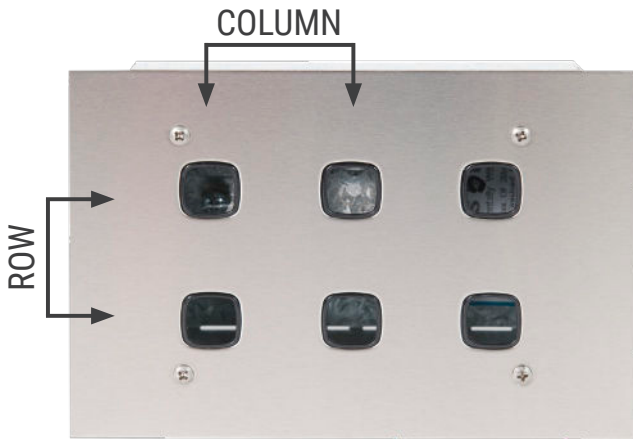

ESM6-BL



ESM12-BL

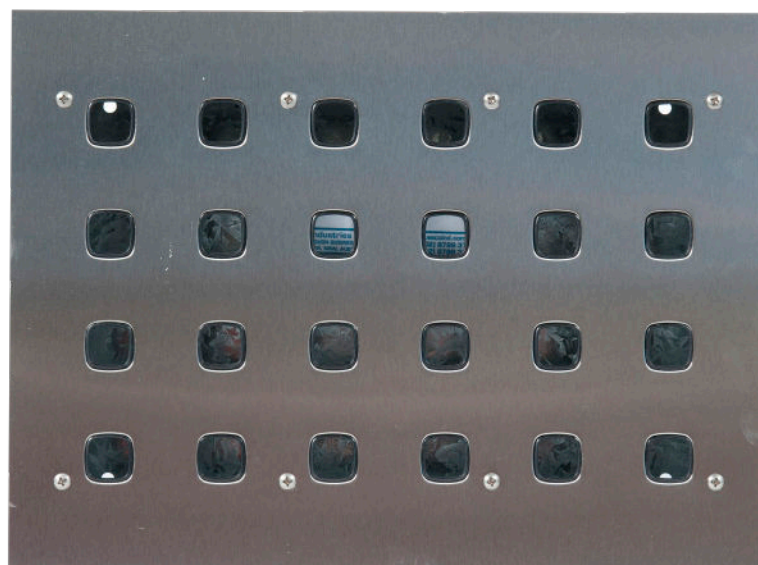

ESM24-BL

## DIMENSIONS

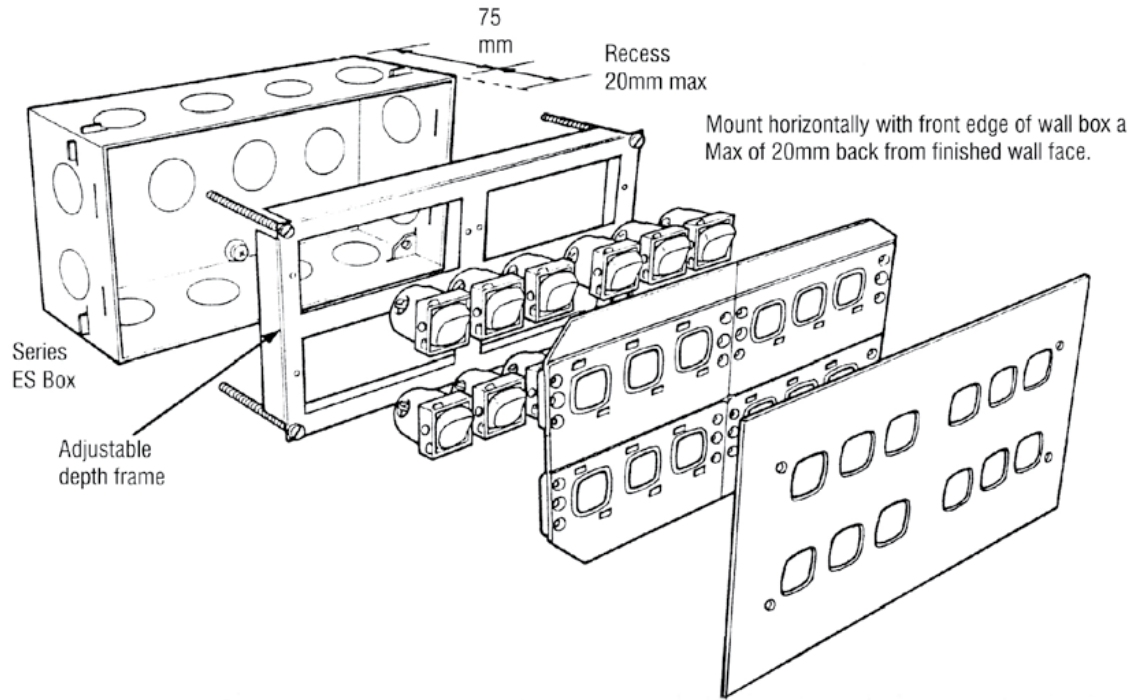

PART NUMBER	NO OF SWITCHES	CONFIGURATION (ROW X COLUMN)		WIDTH OF BOX (MM)	HEIGHT OF BOX (MM)	WIDTH OF PANEL (MM)	HEIGHT OF PANEL (MM)	DEPTH OF BOX (MM)
ESM6	6 WAY	2	3	105	162	129	186	75
ESM8	8 WAY	2	4	105	162	221	140	75
ESM12	12 WAY	3	4	197	116	221	186	75
ESM16	16 WAY	4	4	208	197	232	221	75
ESM18	18 WAY	3	6	289	162	313	186	75
ESM24	24 WAY	4	6	289	208	313	232	75
ESM30	30 WAY	5	6	289	254	313	278	75
ESM36	36 WAY	6	6	289	300	313	324	75
ESM42	42 WAY	7	6	289	346	313	370	75
ESM48	48 WAY	6	8	381	300	405	324	75

OPTIONAL – Front Plate and/or Clip-In label laser engraving available on request



**AUSTRALIA**

89 Egerton St (Cnr Fariola & Egerton)  
 PO Box 6193, Silverwater  
 NSW 2128 AUSTRALIA

T 1300 879 363 F 1300 879 364

customer.service@escoindustries.com.au  
 www.escoindustries.com.au

THE ESCO GROUP OF COMPANIES



**NEW ZEALAND**

Unit 11/273 Neilson St, Onehunga  
 AUCKLAND 1061 NEW ZEALAND

D +64 9 526 1880 Freecall 0800 663 367

customer.service@escoindustries.co.nz  
 www.escoindustries.co.nz

## PART NUMBER

AL0102, AL0204, AL0306, AL0408,  
AL0510, AL0612, AL0714, AL0816,  
AL0918, AL1020

Multigang Stainless Steel Switch Panel

## PART NUMBER:

AL	XX	XX	X	-	XX
NO. OF GANGS	NO. OF SWITCHES	LABEL			SWITCH COLOUR
01 = 1	02 = 2	L = Yes			WE = White
02 = 2	04 = 4	(leave blank) = No			BL = Black
03 = 3	06 = 6				
04 = 4	08 = 8				
05 = 5	10 = 10				
06 = 6	12 = 12				
07 = 7	14 = 14				
08 = 8	16 = 16				
09 = 9	18 = 18				
10 = 10	20 = 20				

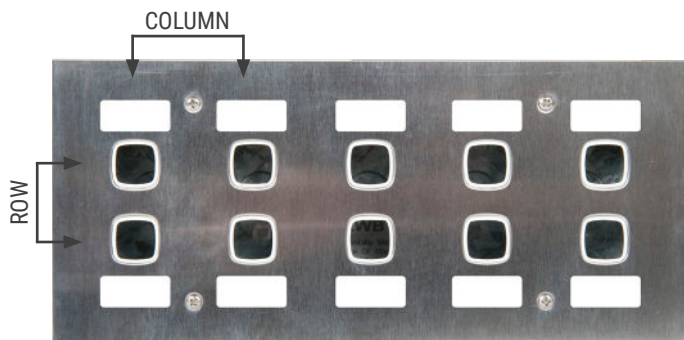

AL0510L-WE

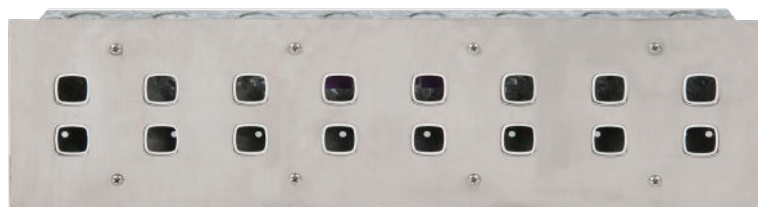

AL0816-WE

PART NUMBER	NO OF SWITCHES	CONFIGURATION (ROW X COLUMN)		WIDTH OF BOX (MM)	HEIGHT OF BOX (MM)	DEPTH OF BOX (MM)	WIDTH OF PANEL (MM)	HEIGHT OF PANEL (MM)
AL0102	2 WAY	2	1	50	100	50	70	120
AL0204	4 WAY	2	2	100	100	50	120	120
AL0306	6 WAY	2	3	150	100	50	170	120
AL0408	8 WAY	2	4	200	100	50	220	120
AL0510	10 WAY	2	5	250	100	50	270	120
AL0612	12 WAY	2	6	300	100	50	320	120
AL0714	14 WAY	2	7	350	100	50	370	120
AL0816	16 WAY	2	8	400	100	50	420	120
AL0918	18 WAY	2	9	450	100	50	470	120
AL1020	20 WAY	2	10	500	100	50	520	120

**NOTE:** NO OPTION FOR 2 OR 4 GANG IN LABEL TYPE

OPTIONAL – Front Plate and/or Clip-In label laser engraving available on request

THE ESCO GROUP OF COMPANIES

## AUSTRALIA

89 Egerton St (Cnr Fariola & Egerton)  
PO Box 6193, Silverwater  
NSW 2128 AUSTRALIA

T 1300 879 363 F 1300 879 364

customer.service@escoindustries.com.au  
www.escoindustries.com.au

## NEW ZEALAND

Unit 11/273 Neilson St, Onehunga  
AUCKLAND 1061 NEW ZEALAND

D +64 9 526 1880 Freecall 0800 663 367

customer.service@escoindustries.co.nz  
www.escoindustries.co.nz